





F2 2D-VS600

M.3	x5	J	x8
		$\varnothing 5 / \varnothing 13\text{mm}$	
Q	x10	S	x10
3,5x16mm		4x20mm	
			



K2 VS600

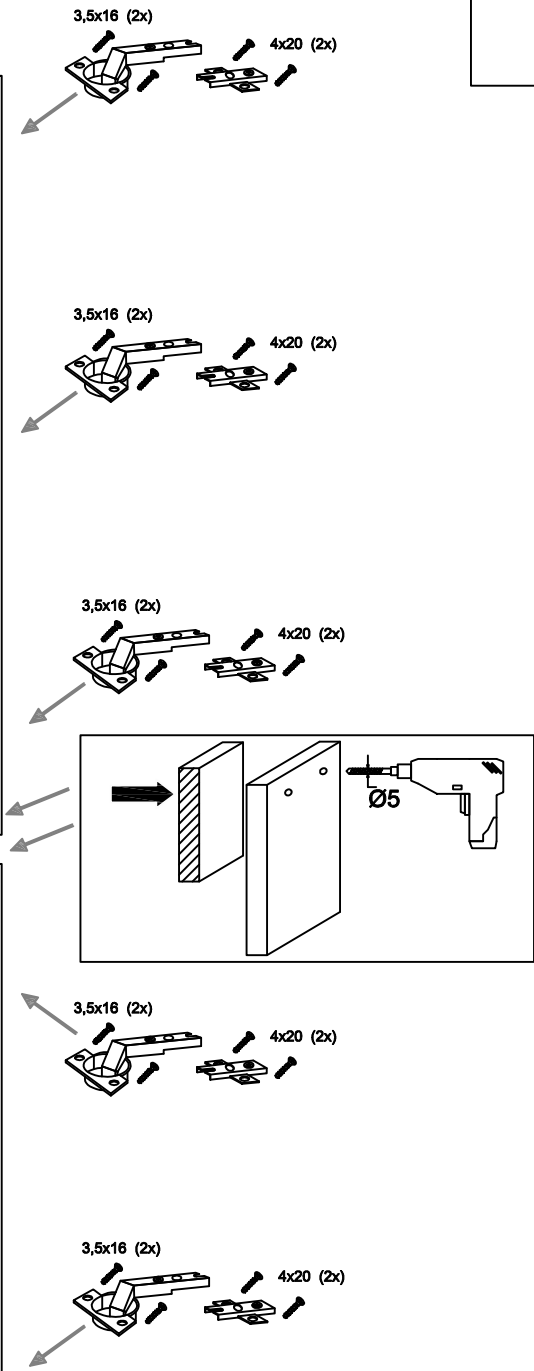
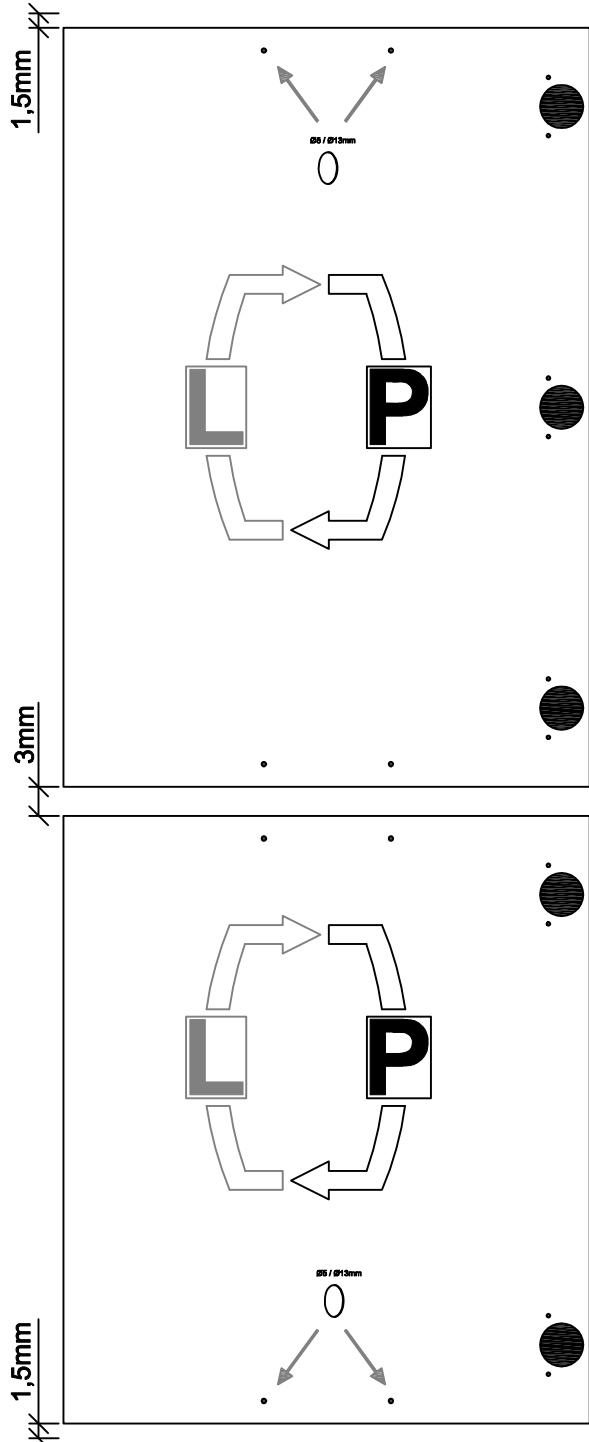
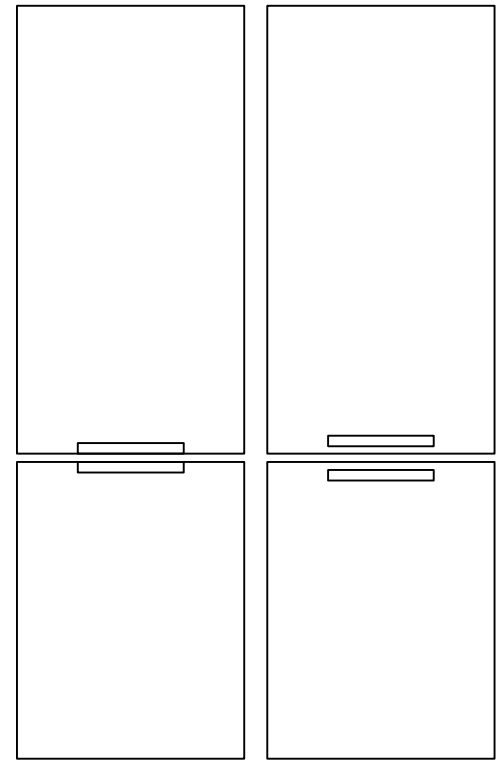